 Supplementary files are available for this work. For more information about accessing these files, follow the link from the Table of Contents to "Reading the Supplementary Files".

Data Quality Control and Improvement of Indirect Human Calorimeter by System Dynamics Approach

Jun FUTAMI¹⁾ and Hiroshi KASHIWAZAKI²⁾

- 1) Organization : Higashi Nippon International University
Postal Address : 37 Suganezawa, Kamata, Taira, Iwaki-city,
Fukushima 970-8567, Japan
Phone : +(81)246-35-0001
Fax : +(81)246-25-9188
E-mail address : futami@tonichi-kokusai-u.ac.jp
- 2) Organization : National Institute of Health and Nutrition
Postal Address : 1-23-1 Toyama, Shinjuku-ku, Tokyo 162-8636, Japan
Phone : +(81)3-3203-5603
Fax : +(81)3-3204-1761
E-mail address : h-kashiw@nih.go.jp

Abstract

Using a system dynamics approach, a simulation model for data quality control and improvement of human calorimeter using the indirect calorimetry (IHC: indirect human calorimeter) was constructed. Accurate measurements of human energy expenditure are necessary in estimating appropriate energy requirement. IHC can measure continuously energy expenditure over 24 hours. O₂ and CO₂ analyzers and flow meter included in the IHC are required to detect accurately the small changes of gas concentration and ventilation rate. Data quality control of each device is important for accurate measurement of energy expenditure. Characteristics of the developed simulation model are that 1) the measurement errors of each device are given separately and artificially, and 2) dynamic change of energy expenditure including those errors can be simulated. The simulation model was applied to examine these characteristics evaluating quantitatively the propagation of each device's error at the IHC in the National Institute of Health and Nutrition, Japan.

Key words: system dynamics, simulation, energy expenditure, human calorimeter and indirect calorimetry

1 Introduction

Accurate measurements of human energy expenditure (EE) over 24 hours are necessary in estimating appropriate energy requirement. Indirect calorimetry is the measurement of the respiratory gas exchange, O₂ consumption (V_{O2}) and CO₂ production (V_{CO2}), which is used to calculate EE. The major advantage of indirect human calorimeter (IHC) is that the subject is unhampered by a close-fitting apparatus such as a facemask for expired air collection. Accurate measurements can therefore be made continuously over periods of 24 hours or more¹⁾⁻⁴⁾. However, the larger instrument has an inherently slow response time, the duration of which is related to the size of IHC and its ventilation rate.

IHC is a unit consisting of O₂ analyzer, CO₂ analyzer, flow meter, thermometer, hygrometer and barometer. Measurement errors of each device are directly incorporated or propagated into determination of EE. The devices included in IHC are required to detect correctly small changes of gas concentration and ventilation rate. To evaluate the error propagation resulting in the large errors for the determination of EE, a simulation model was developed by using a system dynamics approach. In this paper, we describe the developed simulation model and its application to the ethanol combustion experiment. And the usefulness of the simulation model for the data quality control and improvement of IHC is considered.

2 Principle to measure EE with IHC

Fig.1 shows the system diagram of IHC constructed at the National Institute of Health and Nutrition in Japan and the basic equations of the indirect calorimetric measurements⁵⁾. The IHC has a room-sized chamber (about 15,000 [L]) where subject can stay comfortably. Air in the room is exhausted forcibly with a pump at a controlled constant flow rate (about 150 [L/min]) and fresh air is drawn into the room. A small negative pressure is maintained in the room. The room air is mixed sufficiently by fans. Temperature and relative humidity in the room are controlled by air conditioner at constant values 25 [°C] and 55 [%], respectively. O₂ and CO₂ concentrations at both supplying and exhausting sides of the room are measured with gas analyzers. Exhausted air is measured with a flow meter. The exhausted flow rate that is measured under the conditions of ambient temperature and pressure (ATP) is converted to a value under the conditions of standard temperature, pressure and dry (STPD).

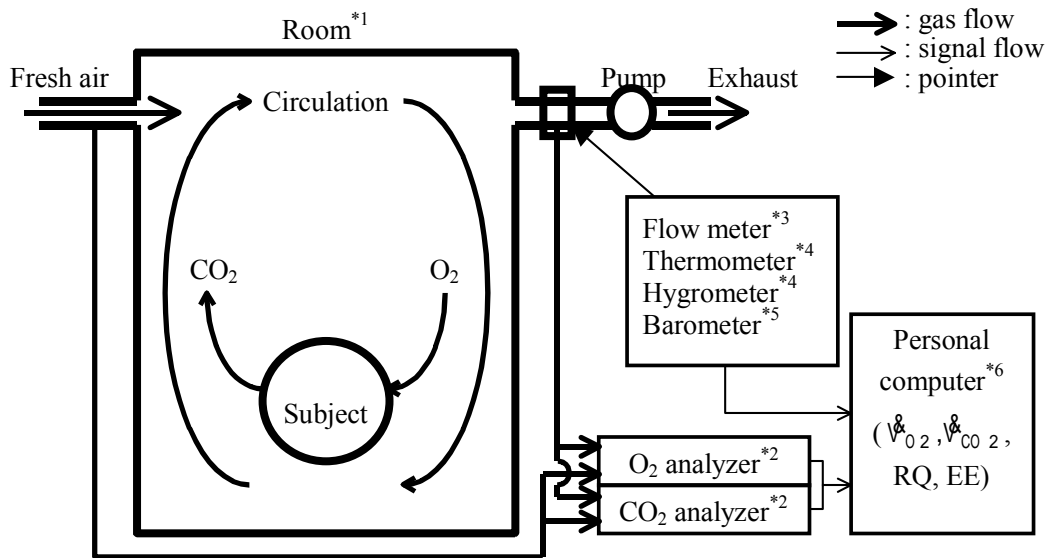

$$EE = 3.9 \cdot \dot{V}_{O_2} + 1.1 \cdot \dot{V}_{CO_2} \quad (\text{Weir's equation}^{6)})$$

$$RQ = \dot{V}_{CO_2} / \dot{V}_{O_2}$$

$$\dot{V}_{O_2} = \dot{V}_S \cdot F_{SO_2} - \dot{V}_E \cdot F_{EO_2}$$

$$\dot{V}_{CO_2} = \dot{V}_E \cdot F_{ECO_2} - \dot{V}_S \cdot F_{SCO_2}$$

$$\dot{V}_S = \frac{F_{EN_2}}{F_{SN_2}} \cdot \dot{V}_E$$

$$F_{SN_2} = 1 - F_{SO_2} - F_{SCO_2}$$

$$F_{EN_2} = 1 - F_{EO_2} - F_{ECO_2}$$

$$\dot{V}_E = \dot{V}_{EATP} \cdot k$$

$$k = \frac{273.16}{273.16 + T} \cdot \frac{P_B - P_{H_2O}}{760}$$

$$P_{H_2O} = 4.58 \cdot 10^{(7.5T/(T+237.3))}$$

Whole IHC system was constructed by Minato Medical Science Co.,Ltd., Osaka, Japan.

*1 Human metabolic chamber, model: FHC-2300S, Fuji Medical Science Co.,Ltd., Chiba, Japan.

*2 Mass spectrometer, model: ARCO-1000A-CH, Arco System Inc., Chiba, Japan.

*3 Pneumotachograph, model: FLB1, Arco System Inc., Chiba, Japan.

*4 Humidity and temperature transmitter, model:HMP-230, Vaisala Oyj., Helsinki, Finland.

*5 Model: PTB-100A, Vaisala Oyj., Helsinki, Finland.

*6 Model: C9821Ra40, NEC Co., Ltd., Tokyo, Japan.

Fig.1. System diagram of IHC constructed at the National Institute of Health and Nutrition in Japan and basic equations of indirect calorimetry.

In this paper, dimension of volume is expressed in STPD except a case mentioned especially. V_{O_2} is determined from the exhausted flow rate and the difference between supplied and exhausted O_2 concentrations. V_{CO_2} is also determined from the exhausted flow rate and the difference between supplied and exhausted CO_2 concentrations. EE is estimated from V_{O_2} and V_{CO_2} by using Weir's equation⁶⁾. Respiratory quotient (RQ) is defined as V_{CO_2}/V_{O_2} and the value, usually 0.7-1.0 in humans, depends on a combustion ratio of energy substrates.

3 Characteristics of IHC measurement

Characteristics of IHC measurements are that 1) O_2 and CO_2 concentrations of the room air change at any time and 2) the levels of changes are very small. The gas expired during a time-period t_1 to t_2 by a subject is exhausted from the room with a delay time, because the subject's expired gas is diluted in the room and the part of the diluted expired gas is exhausted from the room. Effect of the gas expired during the time-period continues for the delay time after time-period. The delay time depends on the time constant of IHC (= room volume / exhausted flow rate). In case of the room volume is 15,000 [L] and the exhausted flow rate is 150 [L/min], the time constant is 100 [min]. To exhaust 95 [%] of the gas expired by the subject during a given time-period (e.g. from t_1 to t_2), three-fold of the time constant are required after expiration. A subject staying in the room breathes continuously, and causes changes in O_2 and CO_2 concentrations at a very small range. In case of the subject at rest, the difference of CO_2 concentrations between supplied and exhausted air is about 0.2 [%] and the rate of change is only about 0.001 [%] per minute. Thus it is important to have an appropriate data quality control system for the accurate measurements of V_{O_2} , V_{CO_2} and EE with IHC.

4 Data quality control of IHC

In general, accuracy and reproducibility of IHC system are evaluated by repeated ethanol combustion tests. Ethanol is made to burn in the room, and the heat production measured with IHC is compared with the theoretical heat determined based on the thermochemical equation of ethanol combustion. Weight of the consumed ethanol for combustion is measured to determine the theoretical amount of heat from Eq.(1) after the combustion. Theoretical RQ of ethanol is 0.666... from Eq.(1). The usual comparison between measured and theoretical values, as shown in Fig.2, can evaluate the overall performance of IHC system including all devices. Measurement errors of each device are included together in the measured endpoint value implicitly. Therefore, the information about “which device should be improved to achieve the acceptable accuracy?” is not obtained from this simple comparison. This comparison also cannot evaluate the accuracy of data measured at every measurement time interval, because the theoretical value is the total heat emitted during combustion period.

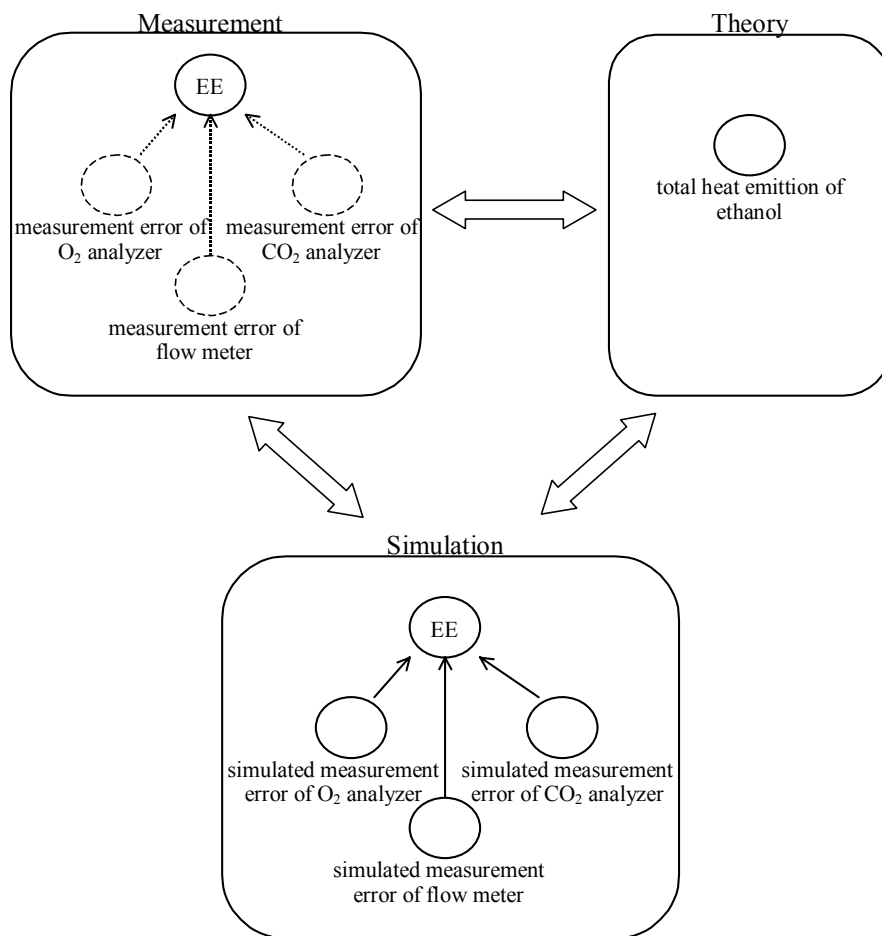
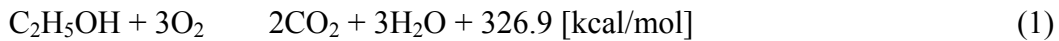

Fig.2. Diagram of data quality control of IHC

Measured EE includes implicitly measurement errors of each device. Theoretical heat is independent of each device's error and total amount emitted during the ethanol's combustion period. Simulated EE includes the simulated measurement errors of each device. Simulation can incorporate propagation of measurement errors of each device into instantaneous EE.

Characteristics of the developed simulation model are that 1) measurement errors of each device of IHC are given separately and artificially, and 2) dynamic change of EE is simulated. The propagation of each device's error to the simulated total heat is estimated quantitatively by the comparison between simulated and theoretical values (Fig.2

). And the propagation of each device's error to the instantaneous V_{O_2} , V_{CO_2} and EE is evaluated quantitatively by comparison between the simulated and measured values (Fig.2). These characteristics are useful for quality control of the data and improvement of IHC.

5 Ethanol combustion experiment and simulation model

5.1 Ethanol combustion experiment

Ethanol combustion experiment was done for examining the performance of simulation model. Alcohol lamp (model: 180-821, capacity: 125 [mL], Yazawa Scientific Co., Ltd., Tokyo, Japan) filled with ethanol (cat.no.:050-00446, purity: 99.5 [%], WAKO pure chemical industries, Ltd., Osaka, Japan) was placed on the balance (model: PB303-S, readability: 0.01 [g], Mettler Toledo Inc., OH, USA) in the empty room of IHC and weighted before ignited. The weight of lamp was measured at 15-minutes intervals during a combustion period. After the combustion for 6 hours, the lamp was extinguished, removed and weighted again. V_{O_2} , V_{CO_2} , EE and RQ were evaluated at 1-minute intervals during 24 hours (combustion period of 6 hours and 18 hours after the combustion) by using the equations of indirect calorimetry (Fig. (1)). These V_{O_2} , V_{CO_2} , EE and RQ have the delay time depending on the time constant of IHC and they are not real time values.

5.2 Simulation model for ethanol combustion experiment

A simulation model was developed based on a principle of the indirect calorimetry for quantitatively evaluating the propagation of each device's error. The simulation model for the ethanol combustion experiment was constructed by using STELLA (High Performance Systems Inc., NH, USA) that is a programming tool based on the system dynamics. We have used the simulation model under the following assumptions:

- 1) The ethanol combustion only affects O_2 and CO_2 concentrations in the room.
- 2) The combustion rate of ethanol is constant during a 15-minutes interval, when the ethanol consumption weight is recorded by change of balance reading.
- 3) All gases in the room are considered ideal and uniform distributions.
- 4) The temperature, relative humidity and pressure in the room are kept constant.
- 5) The O_2 and CO_2 concentrations of the supplied fresh air are constant.
- 6) The flow rate of exhausted air from the room is approximately constant.
- 7) The measurement errors of each device of IHC can be separated into the random measurement fluctuations and constant biases.

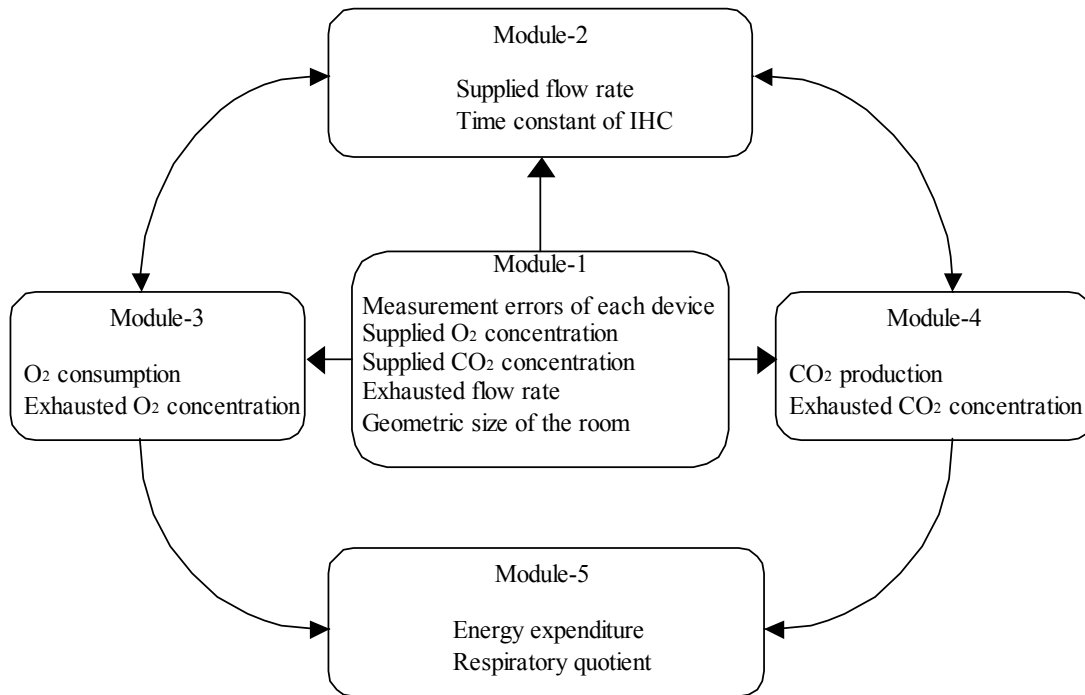

Fig.3. System diagram of simulation model

Developed simulation model included 5 modules, as shown in Fig.3. Random measurement fluctuations and constant biases were given to each device of IHC separately and artificially in the module-1. In the module-2, supplied flow rate (V_S) was calculated taking account of the time constant of IHC. V_{O_2} and V_{CO_2} were calculated in the module-3 and module-4, respectively. EE and RQ were determined in the module-5. Simulation was performed at 1-minute intervals (time interval of simulation $\Delta t=1$ [min]). Each module is described in the following sections.

5.2.1 Module-1

In this module, the random measurement fluctuations and constant biases of O_2 and CO_2 analyzers, flow meter, thermometer, hygrometer and barometer were given (Fig.4). Flow rate of exhausted air from the room (V_E) measured with flow meter was simulated in the form of [“a true value” + a random measurement fluctuation + a constant bias]. The true value was defined as the mean value of all data measured with the flow meter at 1-minute intervals in the past experiment. The following 2 steps determined the random measurement fluctuation of flow meter. First, a maximum measurement fluctuation was defined as standard deviation (SD) of the actual data obtained with the flow meter in the past experiment. Second, the maximum measurement fluctuation (SD) was multiplied the random number from -1 to $+1$ generated every time intervals of simulation. The bias of flow meter was artificially defined as a small constant. The same procedure was used in determining the “true values”, “random measurement fluctuations” and “constant biases” of the measurements in other devices. To examine the

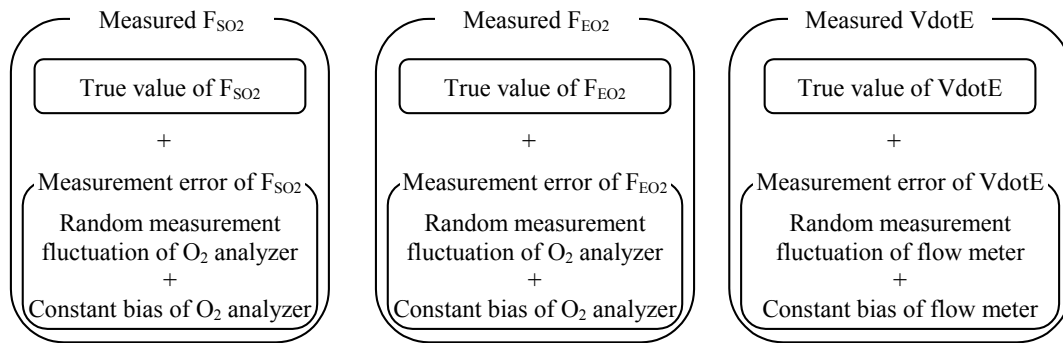

Fig.4. Module-1: Module to define the measurement fluctuations of each device

Measured values of each device were simulated in the form [“true value” + random measurement fluctuation + constant bias]. For example, measured value of $V_E = (\text{true value}) + (\text{maximum measurement fluctuation of flow meter}) \cdot (\text{random number from } -1 \text{ to } +1) + (\text{constant bias of flow meter})$. The true value of V_E and the maximum measurement fluctuation were respectively defined as the mean value and SD of the actual data obtained with the flow meter in the past experiment. The random number was generated every time intervals of simulation. A small constant was artificially given to the bias of flow meter. The same procedure was used in determining the “true values”, “random measurement fluctuations” and “constant biases” of the measurements in other devices.

performance of simulation model, all constant biases of devices were defined as zero in the module-1. The true values and the maximum measurement fluctuations of each device (SD) were presented in Table 1. Geometric room size of 15,960 [L] was also given as V_{R0} in the module-1.

Table 1. True values and maximum measurement fluctuations of each device (SD)

	F_{SO_2} [%]	F_{SCO_2} [%]	\dot{V}_E [L/min,ATP]	T []	RH [%]	P_B [mmHg]
True values	20.931	0.038	154.8	22.3	51.2	756.3
	O_2 analyzer [%]	CO_2 analyzer [%]	Flow meter [L/min,ATP]	Thermometer []	Hygrometer [%]	Barometer [mmHg]
Maximum measurement fluctuations of each device (SD)	0.0025	0.0019	0.4	0.1	0.9	0.7

5.2.2 Module-2

Volume of the room air (V_R) was calculated in this module (Fig.5). V_R was derived from the flow rates of supplied air (V_S) and exhausted (V_E) air, V_{O_2} , V_{CO_2} and the time constant of IHC (TC). Because V_E was controlled to have a constant level in the actual

IHC, we changed \dot{V}_S according to TC. \dot{V}_{O_2} and \dot{V}_{CO_2} used in this module were calculated in the following module-3 and module-4, respectively.

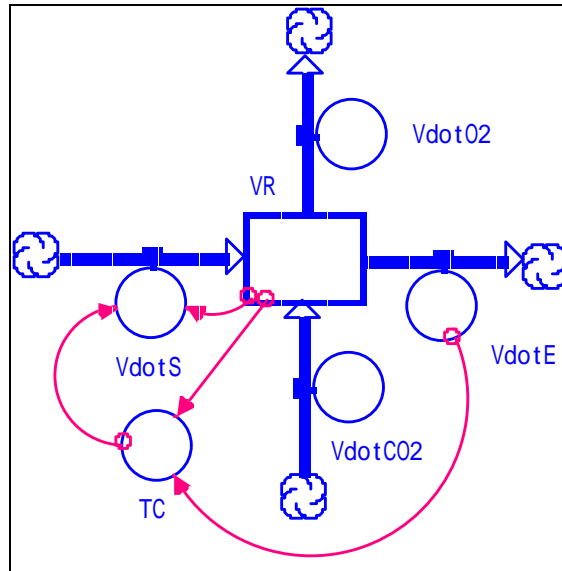

$$\dot{V}_R(t) = \dot{V}_R(t - \Delta t) + (\dot{V}_S(t - \Delta t) + \dot{V}_{CO_2}(t - \Delta t) - \dot{V}_E(t - \Delta t) - \dot{V}_{O_2}(t - \Delta t)) \cdot \Delta t$$

$$\dot{V}_S(t) = (\dot{V}_{R0} - (\dot{V}_R(t) - \dot{V}_{R0})) / TC(t)$$

$$TC(t) = \dot{V}_R(t) / \dot{V}_E(t)$$

$\dot{V}_E(t)$ was defined in the module-1

$\dot{V}_{O_2}(t)$ was calculated in the module-3

$\dot{V}_{CO_2}(t)$ was calculated in the module-4

\dot{V}_{R0} was defined in the module-1

Fig.5. Module-2: Module for calculating the volume of the room air (\dot{V}_R)

5.2.3 Module-3 and module-4

O_2 consumption including the simulated measurement error of O_2 analyzer (\dot{V}_{O_2ME}) and \dot{V}_{O_2} was calculated in the module-3 (Fig.6). \dot{V}_{O_2} was calculated as the difference between flow rates of supplied O_2 (\dot{V}_{SO_2}) and exhausted O_2 (\dot{V}_{EO_2}) air. \dot{V}_{O_2ME} was derived from the following data; \dot{V}_E , O_2 concentrations of supplied (F_{SO_2}) and exhausted (F_{EO_2}) airs, CO_2 production of supplied (F_{SCO_2}) and exhausted (F_{ECO_2}) airs, constant biases and random measurement fluctuation errors of the devices. \dot{V}_E and F_{SO_2} were defined in the module-1. F_{EO_2} was calculated by volume of O_2 in the room (i.e. \dot{V}_{RO_2}/\dot{V}_R). \dot{V}_{RO_2} was derived from \dot{V}_{SO_2} , \dot{V}_{EO_2} and O_2 consumption of ethanol (\dot{V}_{ETO_2}). \dot{V}_{ETO_2} was determined by using both the thermochemical equation of ethanol combustion (Eq. (1)) and the molecular weight of ethanol combustion rate (= weight of actually consumed ethanol for combustion/the time interval noted/molecular weight of ethanol). The combustion rate of ethanol was assumed to be constant during a 15-minutes interval, when the

ethanol consumption weight was measured by change of balance reading. CO₂ production including the simulated measurement error of each device (V_{CO2ME}) and V_{CO2} was calculated in the module-4 by the same procedure as V_{CO2ME} and V_{O2} , respectively.

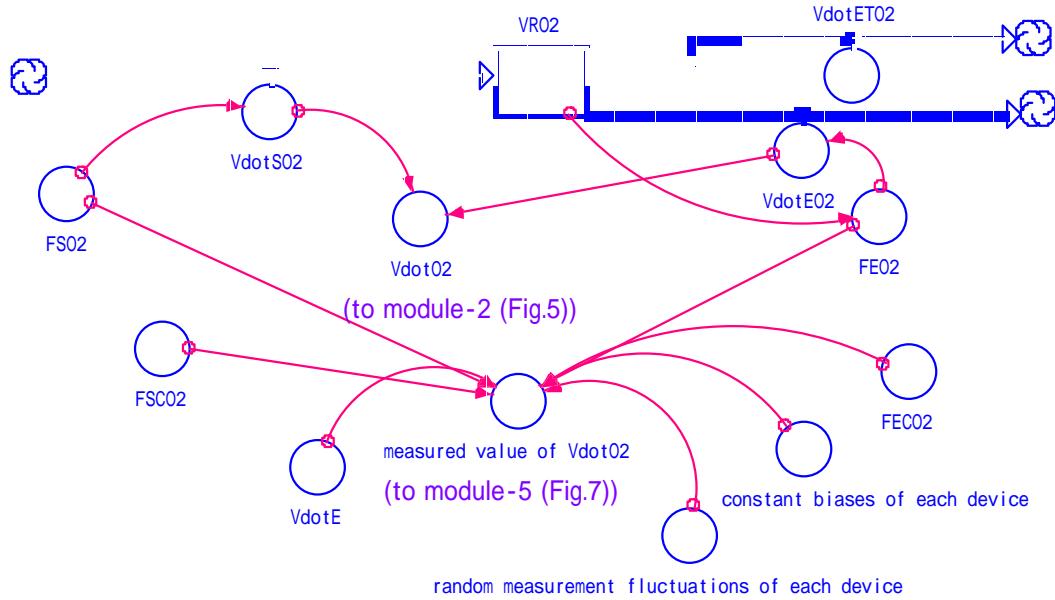

Fig.6. Module-3 : Module for calculating the true O₂ consumption (\dot{V}_{O2}) and the measured O₂ consumption (\dot{V}_{O2ME})

$$\begin{aligned} \dot{V}_{O2}(t) &= \dot{V}_{SO2}(t) - \dot{V}_{EO2}(t) \\ \dot{V}_{SO2}(t) &= \dot{V}_S(t) \cdot F_{SO2}(t) \\ \dot{V}_{EO2}(t) &= \dot{V}_E(t) \cdot F_{EO2}(t) \\ \dot{V}_{O2ME}(t) &= \dot{V}_S(t) \cdot F_{SO2}(t) - \dot{V}_E(t) \cdot F_{EO2}(t) \\ \dot{V}_S(t) &= (F_{EN2}(t) / F_{SN2}(t)) \cdot \dot{V}_E(t) \\ F_{EN2}(t) &= 1 - [F_{EO2}(t) + (\text{random measurement fluctuation of O}_2 \text{ analyzer (t)}) \\ &\quad + (\text{constant bias of O}_2 \text{ analyzer})] \\ &\quad - [F_{ECO2}(t) + (\text{random measurement fluctuation of O}_2 \text{ analyzer (t)}) \\ &\quad + (\text{constant bias of O}_2 \text{ analyzer})] \\ F_{SN2}(t) &= 1 - [F_{SO2}(t) + (\text{random measurement fluctuation of O}_2 \text{ analyzer (t)}) \\ &\quad + (\text{constant bias of O}_2 \text{ analyzer})] \\ &\quad - [F_{SCO2}(t) + (\text{random measurement fluctuation of O}_2 \text{ analyzer (t)}) \\ &\quad + (\text{constant bias of O}_2 \text{ analyzer})] \\ F_{EO2}(t) &= V_{RO2}(t) / V_R(t) \\ V_{RO2}(t) &= V_{RO2}(t - \Delta t) + (V_{SO2}(t - \Delta t) - V_{EO2}(t - \Delta t) - V_{ETO2}(t - \Delta t)) \cdot \Delta t \end{aligned}$$

$V_R(t)$ was calculated in the module-2

$V_E(t)$ and $F_{SO2}(t)$ were defined in the module-1

$V_{ETO2}(t) = (\text{combustion rate of ethanol}) \cdot 3.0 \cdot 22.4$ (during 6 hours combustion period)

$$= 0 \quad \text{(other time)}$$

The combustion rate of ethanol (= weight of actual consumed ethanol for combustion / interval weighting consumed ethanol / molecular weight of ethanol) was assumed to be constant during a 15-minutes interval, when the ethanol consumption is observed by change of balance reading.

5.2.4 Module-5

In this module, using the \dot{V}_{O_2} and \dot{V}_{CO_2} , respiratory quotient ($RQ = \dot{V}_{CO_2} / \dot{V}_{O_2}$), energy expenditure (EE) and total energy expenditure ($\int EE$) were calculated by using the Weir's equation⁶⁾.

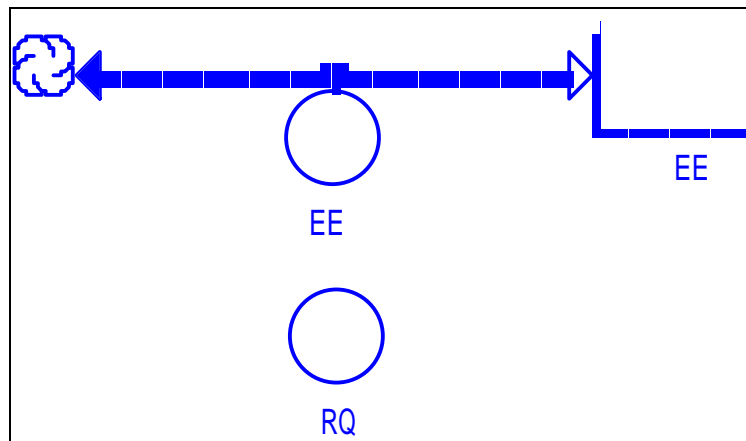

$$RQ(t) = \dot{V}_{CO_2ME}(t) / \dot{V}_{O_2ME}(t)$$

$$EE(t) = 3.9 \cdot \dot{V}_{O_2ME}(t) + 1.1 \cdot \dot{V}_{CO_2ME}(t) \quad \text{Weir's equation}^6)$$

$$\int_{t=0}^t EE(t) = \sum_{t=0}^{t=t-\Delta t} EE(t) + EE(t - \Delta t) \cdot \Delta t$$

Fig.7. Module-5: Module for calculating the respiratory quotient (RQ), energy expenditure (EE) and total energy expenditure ($\int EE$)

6 Results and discussion

Figure 8 shows the result of 8 ethanol combustion experiments. The measured and the theoretically derived total \dot{V}_{O_2} and \dot{V}_{CO_2} data indicate apparently good agreement ($R^2=0.96$ in \dot{V}_{O_2} , $R^2=0.93$ in \dot{V}_{CO_2}). The range of % differences, ([measured value - theoretical value]*100/theoretical value) were -1.6 ~ +2.1% in \dot{V}_{O_2} , and -0.1 ~ +4.4% in \dot{V}_{CO_2} , respectively.

Fig 8: Result of 8 ethanol combustion experiments

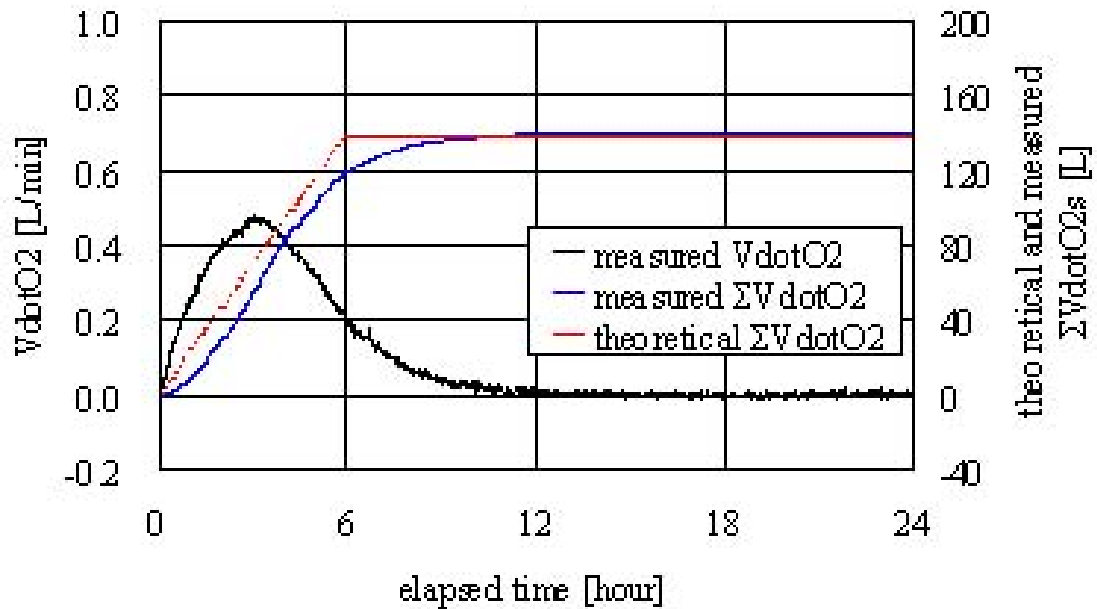
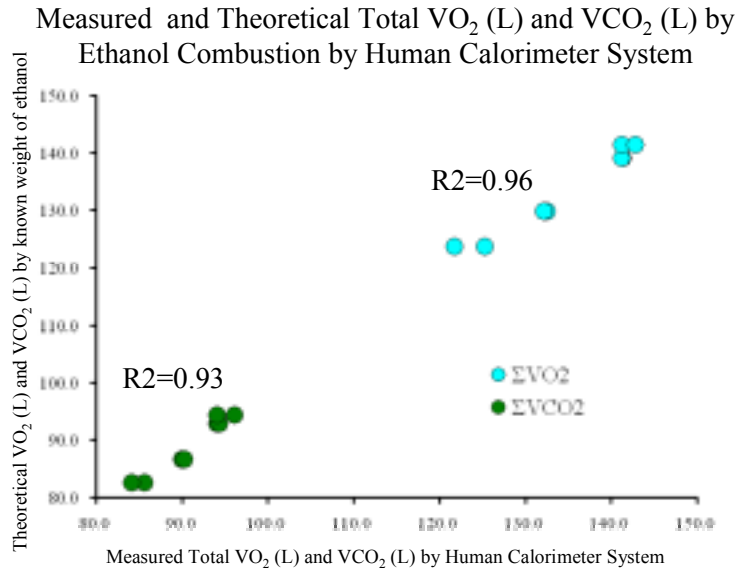

Figure 9A: Theoretical \dot{V}_{O_2} as compared with the measured instantaneous \dot{V}_{O_2} and summation of total \dot{V}_{O_2} ($\Sigma \dot{V}_{\text{O}_2}$).

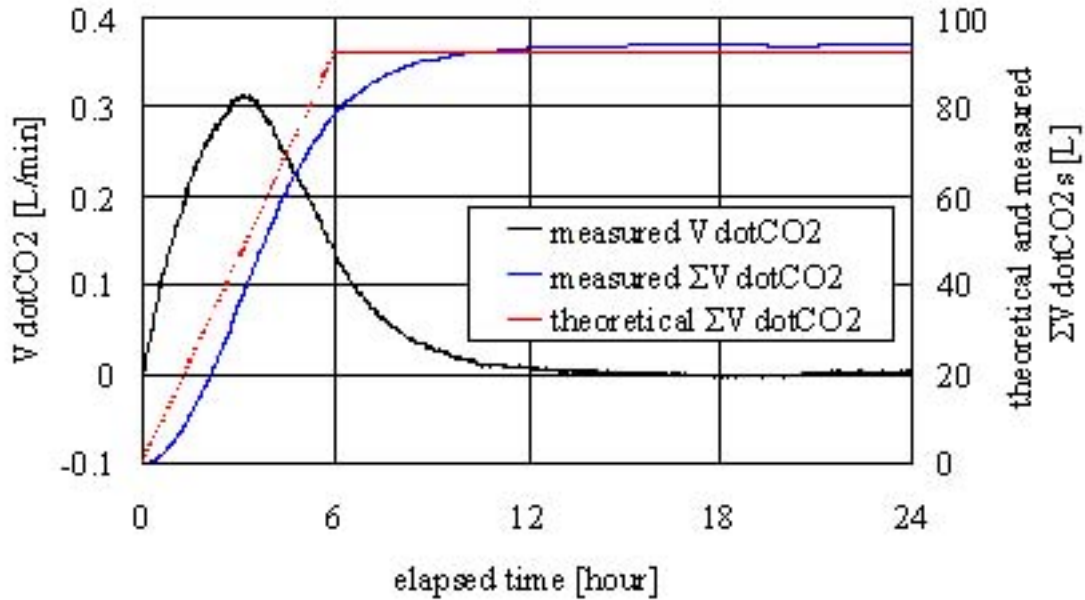

Figure 9B: Figure 9A: Theoretical \dot{V}_{CO_2} as compared with the measured instantaneous \dot{V}_{CO_2} and summation of total \dot{V}_{CO_2} ($\Sigma \dot{V}_{CO_2}$).

Figures 9A and 9B demonstrate the results of one ethanol combustion experiment, which indicate the overestimation of 1.6% in measured \dot{V}_{O_2} and 1.8% in \dot{V}_{CO_2} . By using the Weir's equation for comparative purpose, the heat equivalents in kcal or kJ can be calculated on the same basis. The measured EE in kcal was 1.6% higher than those determined from the theoretically calculated \dot{V}_{O_2} and \dot{V}_{CO_2} of ethanol combustion during the experiment. This value falls well within the acceptable measurement error of the usual indirect human calorimeter system. However, the levels of accuracy would be questionable when the difference between theoretical and measured total \dot{V}_{O_2} and \dot{V}_{CO_2} are much larger than this case as observed in our other ethanol combustion experiments. This is an important point to use the simulation model to evaluate whether the deviation from the theoretical values are due to random error (i.e., random fluctuation due to the observation of a small sample) or systematic errors (i.e., a constant bias accrued from the one of the device in the IHC system).

Figure 10 shows the results of 100 runs for \dot{V}_{O_2} and \dot{V}_{CO_2} as a function of elapsed time using the simulation model, and the measured value obtained from the ethanol combustion experiment. The random errors defined in Table 1 were incorporated into the simulation model. The dynamic behavior of simulated \dot{V}_{O_2} and \dot{V}_{CO_2} agreed well with that of measured data. The mean values of delay time for the 95 [%] of the recovery in the exhaustion of the remained effects of ethanol combustion in O_2 and CO_2 concentrations were 338 [min] (for mean of 100 simulations) and 322 [min] (for experiment). The small difference of 16 [min] indicates that a time constant in the simulations slightly differs from that of actual IHC system.

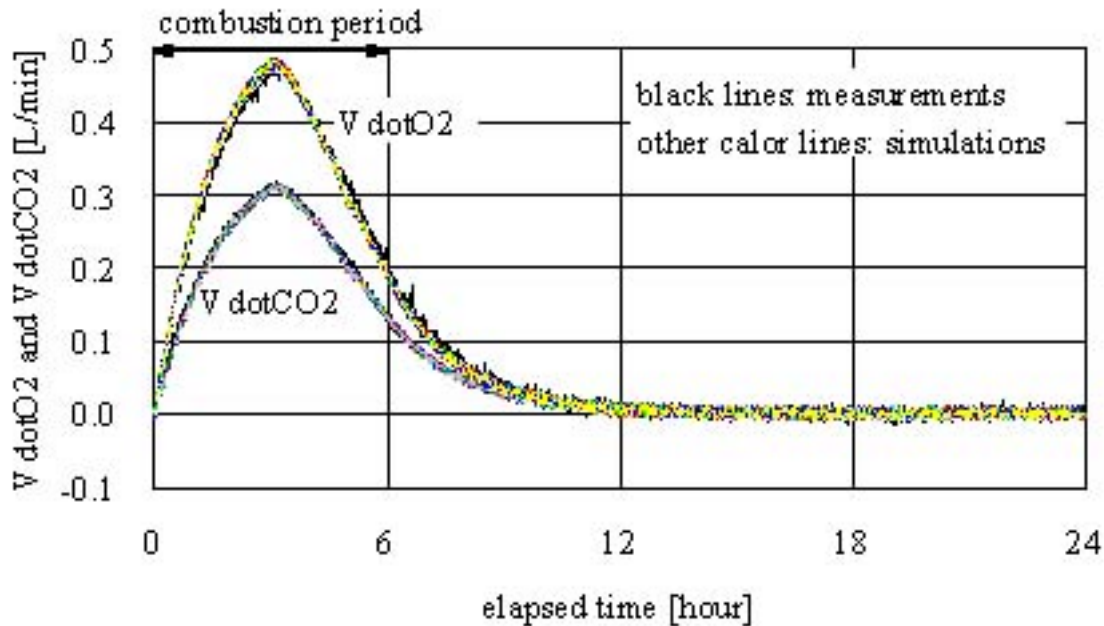

Figure 10: Comparisons of V_{O_2} and V_{CO_2} values between measured data and those derived from the simulation model of 100 runs.

Simulated EEs are compared with measured and theoretical data. The dynamic behavior of simulated EEs agreed well with that of measured data as seen in Figure 10 for V_{O_2} and V_{CO_2} . In the initial phases, the increasing rates of simulated and measured EEs were slower than that of theoretical data because of the delay time. Total heat outputs during 24 hours (24h EE) were 641.8-644.4 [kcal] (mean of 643.2 [kcal]) for 100 simulations and 671.9 [kcal] in the experiment. Differences between these heat values and theoretical value of 675.6 [kcal] were -4.8 ± 0.1 [%] (mean \pm SD) for 100 simulations and -5.3 [%] for experiment. The SD value, ± 0.1 [%], indicates the level of propagation of devices' measurement fluctuations to 24h EE measured with the actual IHC. Although the difference between measured and theoretical heats (-0.5 [%]) slightly exceeded the SD value of simulations (± 0.2 [%]), it is suggested that the simulation model was constructed almost adequately because the mean value of simulated 24h EEs agreed with that of the theoretical heat output.

Simulated RQs ($=V_{CO_2}/V_{O_2}$) during 8 hours after the ignition of alcohol lamp are compared with the measured data in Figure 11. The simulated and measured RQs diverged from the theoretical RQ of alcohol combustion (i.e., 0.667) during the initial 1 hour, and then gradually decreased to a smaller range of variation around the theoretical value. Again the RQ turned into increasing trend of divergence after 6 hours. The ranges of divergence after 8 hours were much greater than those of Figure 11 indicate, because both V_{O_2} and V_{CO_2} become nearly to zero. However, the mean values of both simulated and measure data during 8 hours were 0.667, indicating exactly the same as that of the theoretical RQ.

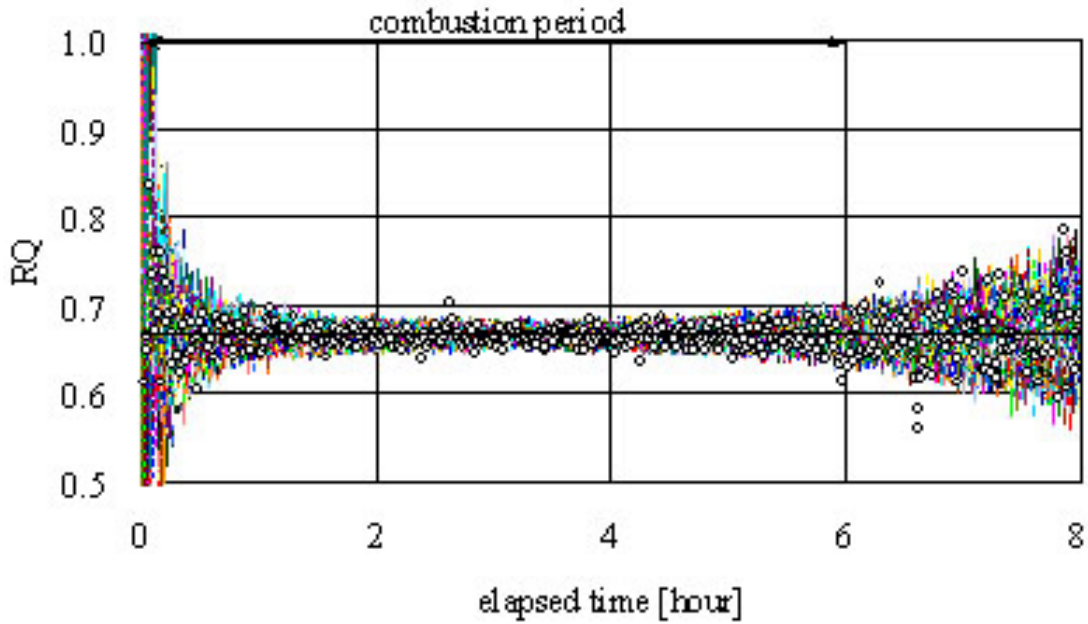

Figure 11: RQ values ($=V_{CO_2}/V_{O_2}$) derived during 8 hours after the ignition of alcohol lamp. The measured data (open circles) and the simulated data (lines with various colors) are shown. The theoretical ratio of V_{CO_2}/V_{O_2} (RQ) derived from ethanol combustion is 0.667 as indicated by a thick black line.

Table 2. Difference between 24 hours EE when the constant biases of both O_2 analyzer and flow meter changed. [%]

Constant bias of O_2 analyzer [%] \ Constant bias of flow meter [L/min]	-0.0030	-0.0015	0	+0.0015	+0.0030
+3.0	6.7	4.4	2.1	-0.3	-2.6
+1.5	5.7	3.3	1.1	-1.3	-3.7
0	4.7	2.3	0 (reference)	-2.3	-4.7
-1.5	3.7	-1.3	-1.1	-3.3	-5.7
-3.0	2.6	-2.3	-2.1	-4.4	-6.7

*Each value was estimated by Eq.(2).

*Each value is the mean of 100 simulations.

*Unit of each value is percent.

Propagation of each device's constant bias into 24h EE was examined by using this simulation model. The differences from the reference simulation data, which did

not include the biases, were calculated using Eq.(2) by comparing the data obtained from the simulation including the small constant biases of devices such as O₂ analyzer and flow meter as indicated in Table 2. Table 2 shows the results of 100 runs indicating the extent of difference expressed as 24h EE when the levels of biases in O₂ analyzer and flow meter changed.

$$\begin{aligned} & \text{Difference of 24h EE} \\ & = ((24\text{h EE})_{\text{biases}} - (24\text{h EE})_{\text{reference}}) / (24\text{h EE})_{\text{reference}} \cdot 100[\%] \quad (2) \end{aligned}$$

When the bias of CO₂ analyzer are manipulated in same manner as indicated in Table 2, the systematic measurement errors obtained from the simulation model in 24h EE were negligible small as compared to the systematic errors observed in the simulations with the biases given to the O₂ analyzer.

If the acceptable error is required within ± 2 [%] for measuring 24h EE by the IHC system, we have to reduce the measurement errors of O₂ analyzer and flow meter less than ± 0.0015 [%] and ± 3.0 [L/min], respectively. Error propagation due to CO₂ analyzer is much smaller than usually anticipated.

We have shown some examples of the data derived from the simulation using the system dynamics for the quality control of the IHC. Finally, we have to emphasize that the data presented here are only a small part of potential usefulness of system dynamics.

Table 3. Difference between 24 hours EE when the constant biases of O₂ and CO₂ analyzers of exhausted air. [%]

Constant bias of O ₂ analyzer [%] \ Constant bias of CO ₂ analyzer [%]	-0.0030	-0.0015	0	+0.0015	+0.0030
+0.0100	4.9	2.5	0.2	-2.1	-4.5
+0.0050	4.8	2.4	0.1	-2.2	-4.6
0	4.7	2.3	0 (reference)	-2.3	-4.7
-0.0050	4.6	2.2	-0.1	-2.4	-4.8
-0.0100	4.5	2.1	-0.2	-2.5	-4.9

*Each value was estimated by Eq.(2).

*Each value is the mean of 100 simulations.

*Unit of each value is percent.

References

- 1) William V Rumpler, James L Seale, Joan M Conway and Paul W Moe, “Repeatability of 24-h energy expenditure measurements in humans by indirect calorimetry“, American Journal of Clinical Nutrition, Vol.51, pp.147-152, 1990.
- 2) Eric Ravussin, Stephen Lillioja, Thomas E. Anderson, Laurent Christin and Clifton Bogardus, “Determinants of 24-hour energy expenditure in man – Method and results using a respiratory chamber –”, The Journal of Clinical Investigation, Vol.78, pp.1568-1578, 1986.
- 3) Donald C. Simonson, and Ralph A. De Fronzo, “Indirect calorimetry: methodological and interpretative problems”, American Journal of Physiology, Vol.258, pp.E399-E412, 1990.
- 4) Eric Jequier and Yves Schutz, “Long-term measurements of energy expenditure in human using a respiration chamber”, American Journal of Clinical Nutrition, Vol.38, pp.989-998, 1983.
- 5) Hiroshi Kashiwazaki, “Recent advance in human energy expenditure measurements”, The Journal of Clinical Sports Medicine (in Japanese), Vol.18, No.4, pp.409-418, 2001.
- 6) J.B. de Weir, “New methods for calculating metabolic rate with special reference to protein metabolism”, Journal of Physiology(London), Vol.109, pp.1-9, 1949.
- 7) J. A. McLean and G. Tobin, “ Animal and human calorimetry ” , Cambridge University Press, 1987.
- 8) P. R. Murgatroyd, P. S. Shetty, and A. M. Prentice, “Techniques for the measurement of human energy expenditure: a practical guide”, International Journal of Obesity, Vol.17, pp.549-568, 1993.
- 9) Toshiro Shimada, “Introduction to System Dynamics”, The Union of Japanese Scientists and Engineers (JUSE) Publications, Tokyo, Japan, 1994.
- 10) James L. Seale, William V. Rumpler and Paul W. Moe, “Description of a direct-indirect room-sized calorimeter”, American Journal of Physiology, Vol.260 (Endocrinol.MeTab.33), pp. E306-E320, 1991.

List of symbols

EE	: Energy expenditure [kcal/min]
F_{ECO_2}	: Fractional CO ₂ concentration of exhausted air from the room [dimensionless]
F_{EO_2}	: Fractional O ₂ concentration of exhausted air from the room [dimensionless]
F_{SCO_2}	: Fractional CO ₂ concentration of supplied air into the room [dimensionless]
F_{SO_2}	: Fractional O ₂ concentration of supplied air into the room [dimensionless]
k	: STPD (Standard Temperature, Pressure and Dry) coefficient [dimensionless]
RQ	: Respiratory quotient [dimensionless]
P_B	: Barometric pressure [mmHg]
$P_{\text{H}_2\text{O}}$: Partial water pressure of the exhausted air [mmHg]
T	: Temperature of the exhausted air []
TC	: Time constant of the IHC system [min]
t	: Elapsed time [min]
Δt	: Time interval of simulation [min]
$V_{\text{CO}_2}, \dot{V}_{\text{CO}_2}$: CO ₂ production [L/min]
$V_{\text{CO}_2\text{ME}}, \dot{V}_{\text{CO}_2\text{ME}}$: CO ₂ production including the simulated measurement error of of . CO ₂ analyzer [L/min]
V_E, \dot{V}_E	: Flow rate of exhausted air from the room [L/min]
$V_{\text{EATP}}, \dot{V}_{\text{EATP}}$: Flow rate of exhausted air from the room under the conditions of ambient temperature and pressure [L/min,ATP] (Dimension of volume is expressed in STPD except a case men tioned especially.)
$V_{\text{ECO}_2}, \dot{V}_{\text{ECO}_2}$: Rate of volume flow of exhausted CO ₂ from the room [L/min]
$V_{\text{EO}_2}, \dot{V}_{\text{EO}_2}$: Rate of volume flow of exhausted O ₂ from the room [L/min]
$V_{\text{ETCO}_2}, \dot{V}_{\text{ETCO}_2}$: CO ₂ production of ethanol [L/min]
$V_{\text{ETO}_2}, \dot{V}_{\text{ETO}_2}$: O ₂ consumption of ethanol [L/min]
$V_{\text{O}_2}, \dot{V}_{\text{O}_2}$: O ₂ consumption [L/min]
$V_{\text{O}_2\text{ME}}, \dot{V}_{\text{O}_2\text{ME}}$: O ₂ consumption including the simulated measurement error of O ₂ analyzer [L/min]
V_R	: Volume of the room air [L]
V_{R0}	: Geometrical room size [L]
V_{RCO_2}	: Volume of CO ₂ in the room [L]
V_{RO_2}	: Volume of O ₂ in the room [L]
V_S, \dot{V}_S	: Flow rate of supplied air into the room [L/min]
$V_{\text{SCO}_2}, \dot{V}_{\text{SCO}_2}$: Rate of volume flow of supplied CO ₂ into the room [L/min]
$V_{\text{SO}_2}, \dot{V}_{\text{SO}_2}$: Rate of volume flow of supplied O ₂ into the room [L/min]