

# **WATER RESOURCES DEVELOPMENT PLANNING**

By

Ali N. Mashayekhi  
Department of Industrial Engineering  
Sharif University of Technology  
Tehran, Iran.

March 1989

## **ABSTRACT**

Water resource development requires development and operation of expensive facilities. Planning, design, and execution of water resource projects in Iran have been taking a period of time much longer than what is considered as a normal time. In addition, the projects are costing much more than normal. This paper presents a system dynamics model to analyze the behavior of the water resource development system. The paper shows that high cost and long construction time are results of policies that govern decisions related to budget allocation, start of new projects, and price of water. The paper shows that how alternative policies could improve the behavior of the system. It is argued that appropriate planning approach for water resource development should consider the feedback mechanism in the water resource development system and concentrate on design policies that control the behavior of the system through those feedback loops.

## **INTRODUCTION**

Water resource development requires construction and operation of expensive facilities such as dams, channels, and drainage system. Each year billions of Rials in Iran are spent in feasibility studies, design, construction, and operation of such facilities. Planning and budgeting of water resource development tend to be based on a traditional approach in which goals are set, programs to achieve the goals are developed, and the resources to implement the programs are requested.

However, water resource development is not taking place effectively and efficiently. Projects completion time and cost are much larger than originally planned. In order to improve the development effectiveness and efficiency in the water industry, planning and control processes should be changed. High level management should focus on design and implementation of a new planning system in which attention is paid to the feedback loops which control the behavior of the system. The new system should identify the important control points in the feedback loops and provide appropriate rules to regulate the whole system from such control points in an effective and efficient way.

A system dynamics model is developed to help management in designing appropriate decision rules in order to improve the behavior of the water development system. The model is presented in this paper and behavioral results of different policies or decision rules are examined.

## **WATER RESOURCE DEVELOPMENT SYSTEM**

Water system consists of five sectors: water supply facilities to control surface and ground water resources, distribution channels which transfer water from supply facilities to agricultural lands, transfer pipelines which transfer water from supply facilities to city distribution network, city water refinery and distribution network, and water sewages.

Development of new facilities, as shown in Figure 1, consists of planning, feasibility study, design, construction, and operation

## **WATER RESOURCE DEVELOPMENT PERFORMANCE**

Performance of water resource development has not been satisfactory in Iran. The completion time of projects has been long. Currently, the ratio of the amount of money needed to complete the projects under design and construction to the annual development budget of the water system is about 75 years (4). The value indicates that in terms of available money it will take on average about 75 years to finish current projects which is much longer than the normal time.

Low budget relative to what is required and long construction period would increase project costs. When a project starts, it will have some fixed cost. The fixed cost occurs as long as the project continues. When the completion time increases, the total fixed cost of the projects rises and projects become more expensive. As projects become more expensive, with a certain amount of budget fewer projects can be finished and less amount of water resources can be developed.

Long construction period and high construction cost are indication of low performance of water resource development. Such low performance is due to planning approach in which feedback loops are not considered (3) and policy design is not the focus of the planning.

## **A SYSTEM DYNAMICS MODEL FOR WATER DEVELOPMENT PLANNING**

### **Overall Structure**

Water development system consists of five different sectors: Water supply facilities, water distribution and draining channels, water transfer facilities to cities, city water distribution facilities, and city water swages facilities. As shown in Figure 1, development of each sector consists of five stages: Development planning, feasibility study, engineering design, project construction, and operation.

Flow of projects through different stages in each sector can be conceptualized by a series of rate and level variables (1&2). Figure 2 shows the flow of projects during development process for water supply facilities. The flow of projects in other sectors of water development system is similar to what is shown in Figure 2.

### **Major Decision Points**

In Figure 2, rate variables represent decision points in the system.

### **Major Decision Rules:**

For the sake of simplicity, in this paper, only two sectors are considered. Some of the major decision rules in these two sectors are the followings..

#### **Allocation of Budget Between Different Sectors:**

Completion rate of projects in different sectors and stages depend on the allocated budget to those sectors and stages. Two alternatives for allocation of total budget between water supply and water distribution sectors are considered. Total budget is allocated proportional to the desired budget in each sector. In one alternative which is in accordance with the current policies, the desired budget in each sector is determined based on work in process in different stages of that sector. Alternatively, the desired budget can be determined to bring in balance the capacities of water supply and water distribution sectors.

#### **Starting Rate of Projects in Different Stages**

Another major decision rules are related to the starting rate of projects in different stages. The starting rate of feasibility study is based on the difference between the forecast of demand for water and water supply projects under study, design, construction, and operation. The starting rate also depends on the ratio of allocated budget to desired budget for water supply sector. A lower budget decreases the starting rate.

The starting rate of projects in design and construction stage, according to current policies, are proportional to feasible projects and designed projects. It is assumed that on average 6 months after feasibility study is completed, design stage starts and 6 months after design stage is completed, construction phase starts.

Another alternative is to formulate starting rate as a function of the amount of available budget to finish projects under design or construction relative to the desired budget to finish those projects during a normal time. Under this alternative, the starting rates depend on available budget and projects in the previous stage. If all the desired budget is allocated then starting rates are a constant fraction of projects in the previous stage. When all required money is not available, then starting rate is decreased.

#### **Inactivating Rate of Work in Construction Stage**

Another policy governs the inactivating rate of projects under construction. Under one policy alternative, inactivating rate is zero. Under another alternative, inactivating rate is a function of desired projects under construction relative to actual projects under construction. Desired projects under construction is a function of allocated budget for construction projects. When projects become inactive, their fixed cost decreases to a lower level relative to when they are active. In addition, inactive projects do not require any variable budget which make construction progress possible.

### **Pricing Policy.**

Another decision point that is not shown on Figure 2 is pricing decision. Currently the nominal price of water is constant. Under current pricing policy the real price of water decreases when inflation raises the general price index. Alternative pricing policy can be adopted.

### **Cost Structure in Construction Stage**

In construction stage two kinds of cost are recognized: fixed cost and variable cost. Fixed cost is the minimum annual budget that is required to keep construction projects for one unit of water supply capacity ready for physical progress. The second kind of cost is variable cost. The variable cost is the cost that should be paid to finish construction of one unit of water supply capacity. Average unit cost of water supply projects is unit variable cost, which is constant, and average accumulated fixed cost for unit of water supply capacity. When duration of construction rises, accumulated fixed cost increases and raises the unit cost of the projects.

### **MODEL BEHAVIOR AND POLICY DESIGN.**

#### **The Base Run**

The base run shows the behavior of the model under current policies. Policy assumptions of the base run are: (1) Budget allocation between different sectors and different stages is based on desired budget for work in process in the sectors and stages. (2) Starting rate of projects in different stages is based on the amount of projects in the previous stage. (3) Inactivating rate of the projects in the construction stage is zero. (4) Price of water is constant. (5) Starting rate of feasibility study is a function of discrepancy between projected demand for water and sum of water supply capacity under operation, construction, design, and study. The starting rate also depends on the allocated budget relative to the desired budget. (6) Total development budget for water facilities is constant after 1985. With the base run policies the behavior of the model is shown in Figure 3.

In the base run, because of the pressure from demand, starting rate of feasibility study increases and raises the number of feasible projects. Feasible projects move automatically forward into design stage and finally construction stage. Projects under construction increases. When projects under construction increases, fixed cost to keep projects ready for progress in construction rises. When total budget is constant and fixed budget increases, then remaining budget for construction work decreases and completion rate of projects under construction fall. When completion rate falls, projects under construction rises more rapidly and causes fixed cost to increase to a higher value. As fixed cost rises, unit cost of projects increases. With higher unit cost and a constant development budget fewer projects can be completed.

#### **New Policies for Starting Rates**

In this section relative to the base run, some addition factors affect the starting rate. The starting rate of feasibility study is adjusted based on feasible projects relative to the average starting rate of engineering design. When feasible projects relative to the start of design increases, which means enough feasible projects are available to feed design activities, then start of feasibility decreases. Similarly, the starting rate of design is adjusted based on designed projects relative to the start of construction. The

starting rate of construction is adjusted based on available budget. When allocated budget is less than desired budget, starting rate decreases and vice versa. The behavior of the model with this new policy is shown in Figure 4.

Because the starting rates of feasibility study and design are adjusted based on feasible projects and designed projects, respectively, and the start of construction is adjusted based on available budget, the system should not be overloaded with projects as much as in the base run. However, still pressures from demand causes the new projects to be started and accumulation of projects in the construction stage increases the total fixed cost and decreases the completion rate. As a result, the behavior of the system is not much different from the base run.

### Inactivating Policy

In this section in addition to the new starting rate policies, some of the projects in construction stage are inactivated when the available budget is less than desired. Inactivated projects have a lower fixed cost relative to active projects. Inactivated projects are activated when insufficiency of budget disappears. No construction activities take place in inactivated projects and therefore no money is spent as variable cost. The behavior of the model with new policies is shown in Figure 5.

Inactivating of excess projects under construction decreases fixed cost of projects under construction. Lower fixed cost lets more money available for construction activities and increases completion rate of the projects.

### A Higher Price for Water

In this section, in addition to starting rate policies and inactivating rate policy, the price of water is increased. The behavior of the model is shown in Figure 6. Higher price of water increase the amount of money available to the water development system. As a result completion rate increases and let the water supply facilities to rise during the simulation.

### REFERENCES:

1. Richardson G. and Pugh J., Introduction to System Dynamics Modeling with DNAMO, MIT Press, 1980.
2. Richmond, et al., Computer Simulation, An Academic User's Guide to STELLA, High Performance System, 1986.
3. Sterman J.D. 1987, Misperceptions of Feedback in Dynamic Decision Making, Organization Behavior and Human Decision Processes.
4. Mahabe Ghods, 1989, "Niazhaie Tarhaie Omrani Ab", in Farsi, Mahabe Ghods.



Figure 1: Stages of water development system in each sector.

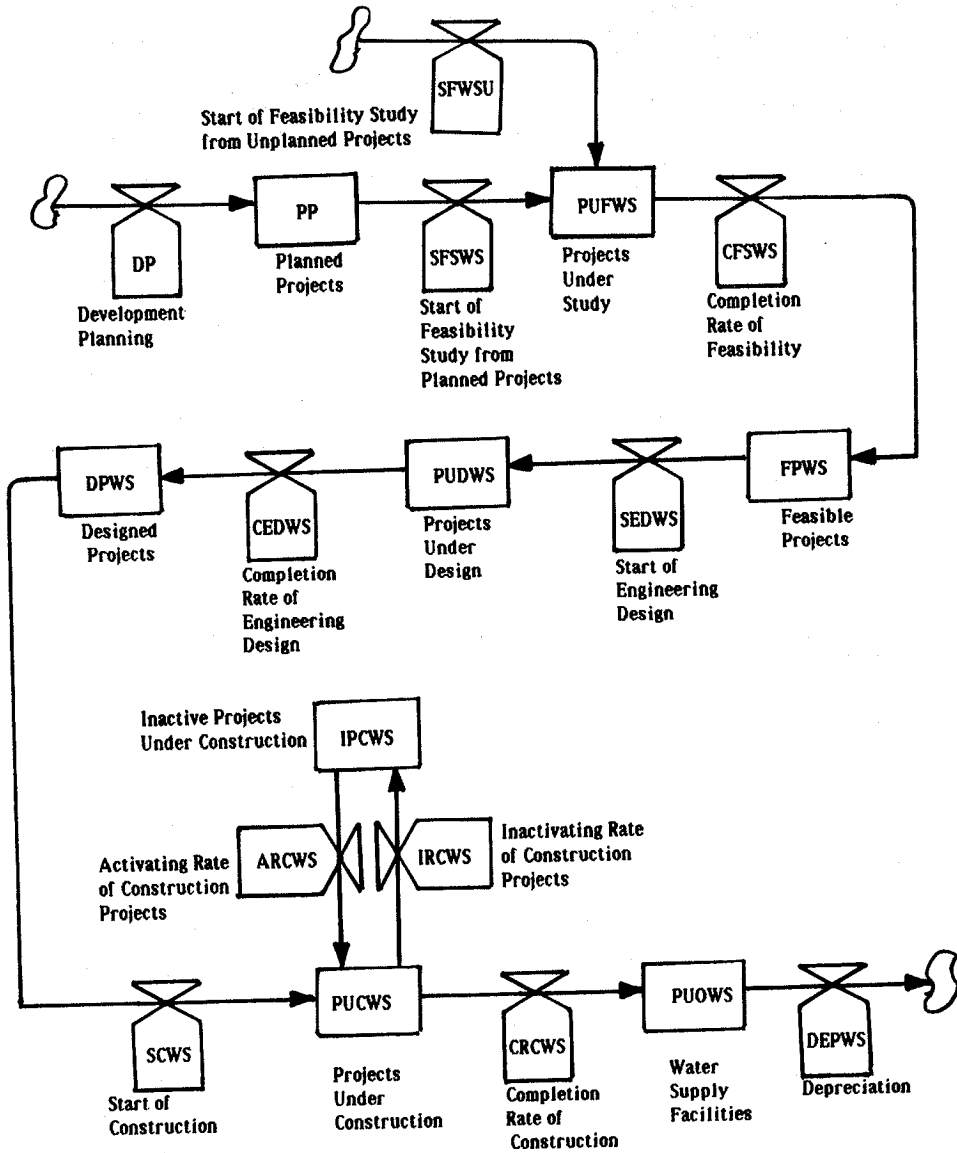

Figure 2: Flow of projects in water development system.

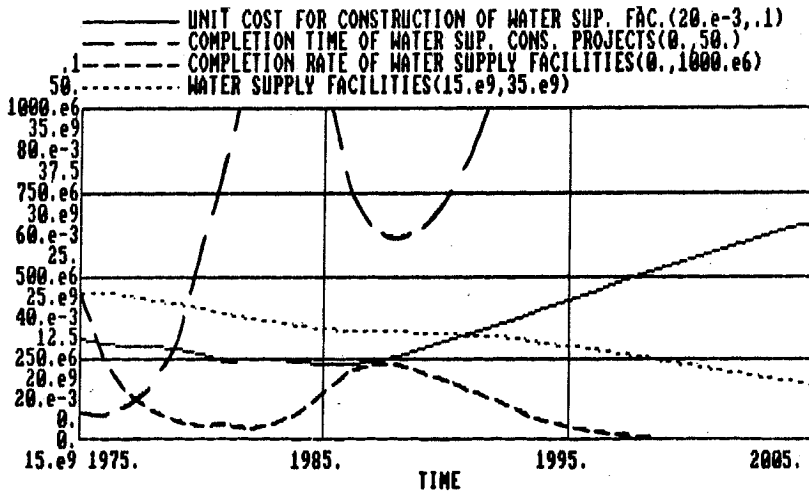

Figure 3: The Base Run: Behavior of Water Supply Facilities.

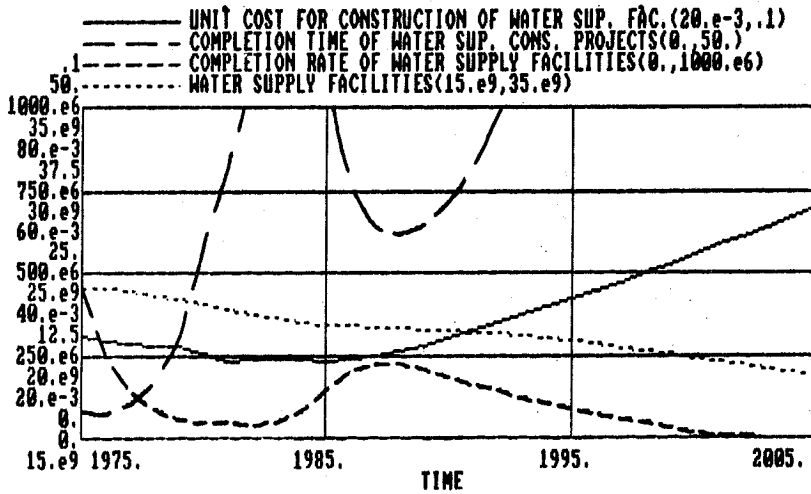

Figure 4: New Policies for Starting Rates: Behavior of Water Supply Facilities.

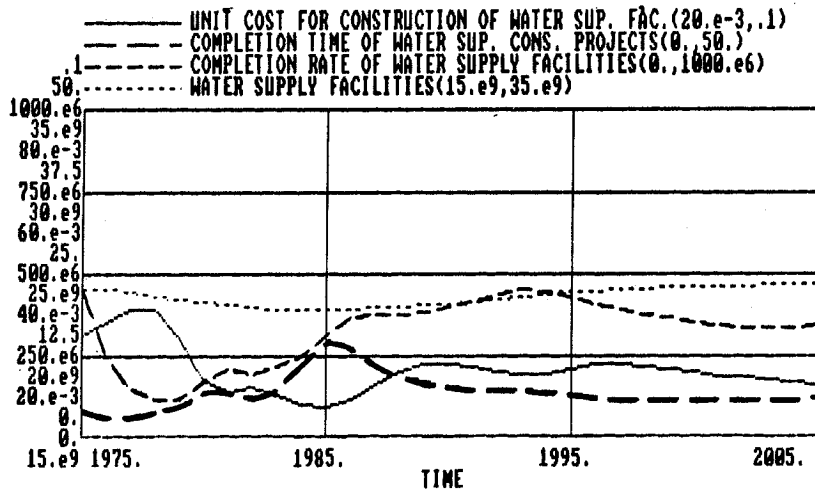

Figure 5: Inactivating Excess Construction Projects.

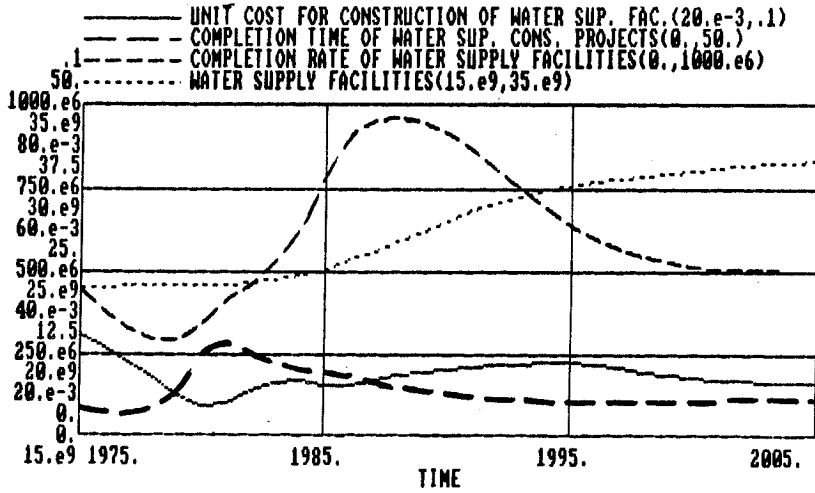

Figure 6: A Higher Price for Water.